

Technical
Drawing

Desenho
Técnico

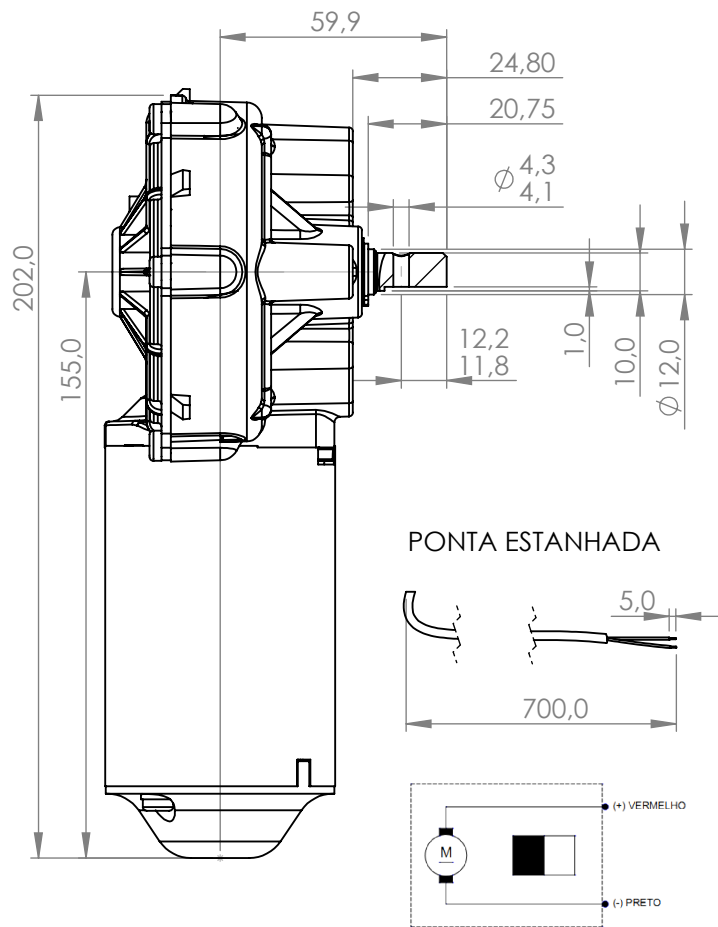
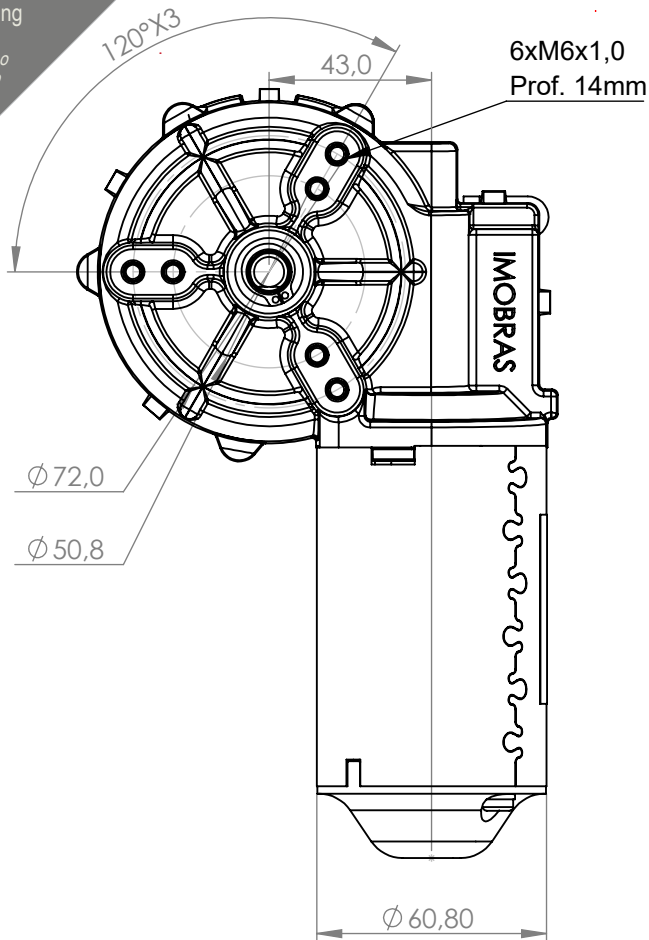

Technical
Specification

Especificação
Técnica

Imagem
Ilustrativa

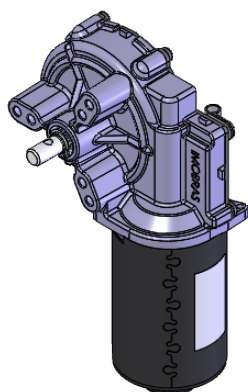

NOTAS:
Aplicação: Industrial

NOTES:
Application: Industrial

100503924

CARACTERÍSTICAS ELÉTRICAS	
U _N (V)	27
P _N (W)	35
n _N (rpm)	55
I _N (A)	3
I _{max} (A)	18,5
M _N (Nm)	6
M _{max} (Nm)	30
i	55:1
Rotação	L / R
Peso (Kg)	1,500

